

Development of a test setup for exploring the potential of haptic feedback for maritime operations

F Hoeckx* MSc, A Vrijdag** MSc PhD, D A Abbink* MSc PhD

* *Department of Cognitive Robotics, 3mE Faculty, Delft University of Technology, The Netherlands*

** *Department of Maritime & Transport Technology, 3mE Faculty, Delft University of Technology, The Netherlands*

Corresponding Author: A.Vrijdag@tudelft.nl

Synopsis

When human operators control complex machines, haptic feedback on the control interfaces can reduce operator errors and workload and increase situational awareness. Such benefits have been demonstrated during control of vehicles, drones, remote-controlled robots, but the maritime industry has so far largely ignored the potential of haptic feedback on the control interface of vessels. This paper aims to illustrate such potential.

First, three vessel control schemes are provided to illustrate similarities and differences in: manual control, supervisory control of an autopilot, and manual control while assisted by haptic feedback. Second, the design of a maritime simulator with active control levers is described, that allows exploration of the potential of haptic feedback for ship propulsion and manoeuvring control. An actuated 2-DOF azimuth control lever was designed, that can not only *command* engine speed and thruster azimuth angle by providing a position input, but that can also *provide haptic feedback* by generating force feedback in both degrees of freedom. Two such levers were constructed and were programmed to communicate with a commercial ship simulation environment, in which a scenario of a harbour tug navigating towards the next waypoint was programmed. A haptics software module was designed to allow easy programming of various types of assistive haptic feedback: virtual hard stops, damping fields, vibrations and repulsive or attractive forces. A real-time visualisation of the operation and the relevant signals is presented on multiple computer screens.

Third, this paper describes the implementation of three different types of haptic feedback to support navigation towards a waypoint: vibrations when heading errors exceed a certain boundary; repulsive forces that assist in steering away from certain boundaries; and assistive forces to guide towards a waypoint.

It is concluded that the developed maritime haptic simulator allows for human-in-the-loop experiments to explore potential benefits of haptic feedback for maritime applications: we could stably and reliably implement various force feedback designs based on task-related information from the simulated environment. This work also paves the way for developing operator support systems for other, more complex tug operations, as well as support for remote control of (semi-)autonomous ships.

Keywords: Haptics; Force Feedback; Tug; Human-in-the-loop experiments; Bridge simulator; Remote controlled ships

1. Introduction

The common impression often portrayed is that 80% of all maritime accidents are caused by human error (Donaldson et al., 1994). But – similar to aviation (Billings, 1997) – the underlying causes often revolve around issues with human-machine interface design, of support systems that potentially cause information overload, or stimulate improper use of automation. A recent human-centred review of marine accident investigation reports in the CyClaDes project (CyClaDes, 2016) identified that 67% of the accidents involved Human-Machine Interface (HMI) issues. The number and severity of such accidents may even increase, given the congestion caused by increasing traffic density and restriction of sea lanes (e.g. by wind farms and environmental areas), and the ever-increasing demands on cost-effectiveness. Coping with these challenges should not be pursued merely by better selection and training of crew, but also by facilitating crew in their task by improving onboard HMI design.

Without a radical innovation in interface design, “the human is destined to be the limiting factor in any human-machine system” (Bias R., Lewis C., Gillan D., 2014). But how to radically innovate? The focus of

Author's Biographies

Frank Hoeckx works as a Research Engineer in the Delft Haptics Lab, Department of Cognitive Robotics at Delft University of Technology. He completed a MSc degree in Mechanical Engineering at Delft University of Technology. His interests include human-machine interaction, robotics, haptics, and shared control.

Arthur Vrijdag is an Assistant Professor in the Department of Maritime & Transport Technology at Delft University of Technology.

David Abbink is an Associate Professor in the Department of Cognitive Robotics at Delft University of Technology.

traditional interface design is on visual displays and warning systems, or traded control with partially autonomous systems, each with their own issues (Sheridan, 2002).

One future direction to explore for the maritime industry is haptic human-automation interaction (Abbinck et al., 2012), that has shown promise as a physical, bidirectional communication interface. It is based on clearly communicating the actions of an automation system through forces on the control interfaces, supplementing visual interfaces, increasing situational awareness, and allowing a rich, mutually adaptive physical interaction between the operator and the machine intelligence. Haptic human-automation interaction has been successfully developed as haptic steering wheel guidance in the automotive domain (Griffiths and Gillespie, 2005; Mulder et al., 2012), as haptic assistance for tele-operated robot arms (Rosenberg, 1993; Boessenkool et al., 2013), as a haptic flight director in an aircraft (De Stigter et al., 2007), and as a haptic gas pedal (Mulder et al., 2008) to support car-following, which has been commercially released by Nissan. In general, the benefits of haptic human-automation interaction include improvements in primary and secondary task performance at reduced physical and mental workload, and better awareness of the automation system status and intent.

2. Background on Haptics in Vehicle Control

So what is haptics? The word derives from the Greek word for the sense of touch, and is used in literature to either denote haptic devices that have been engineered to display forces to the user; or to denote the physiology of human perception (through tactile sensors in the skin and through proprioceptive sensors in the muscles, tendons and ligaments). The human control enabled by proprioceptive sensors is extremely adaptive and fast (25ms time delay between proprioceptive perception and reflexes (Mugge et al., 2010); compared to 200ms for the visual system), processing and responding to information at a subconscious level. Unfortunately, it is used less and less in interface design – or, if it is used, merely as warning vibrations that attract attention but do not enable the fast proprioceptive control.

Interestingly, bi-directional haptic interaction lies at the root of many vehicle control applications. The control of ship sailing direction started with direct control of a tiller by the helmsman, and later evolved to a mechanical servomechanism, with pulleys that amplify the force provided by the helmsman. These systems allowed the helmsman to feel the forces that interacted on the rudder. Nowadays most rudders are driven by an electro-hydraulic steering gear, where the command by the helmsman is an electric signal which drives one or more hydraulic control valves. This means that the actuator is mechanically decoupled from the rudder, removing the haptic feedback for bi-directional communication. The commands are unidirectional, and the only way that the helmsman can receive feedback is via visual indicators on the bridge panels, or auditory feedback from crew or warning systems. This is similar to the fly-by-wire developments in aviation (Billings, 1997), where in an Airbus the plane is controlled by a passive side-stick that does not haptically convey the actions of the co-pilot or autopilot. Similarly, drive-by-wire has been introduced in the automotive industry, where the feel for the road needs to be re-engineered somehow.

In short: by-wire technologies enable flexible engineering of relationships between control input (steering wheel/side stick/tiller) and the vehicle controlled element (tyres/flaps/rudder); and allow amplification of forces, filtering, and computer assistance - at the cost of removing the bi-directional haptic interaction. This can cause visual overload, reduced awareness of underlying support systems, potentially harming safety and performance. We propose to address this by using haptics to enhance control through computer assistance: haptic human-automation interaction.

3. Haptics in the Maritime Environment

Related work on haptics onboard ships is limited and mainly focuses on the mechatronics of the haptic stick design. Prada et al (2016) recently described the design and control of a haptic lever for speed control with virtual limits. Bjelland et al (2005) described the effect of changing the throttle sticks of a Fast Patrol Boat from the original mechanical/pneumatic system to electronic sticks. They emphasize the importance of the haptic properties, especially in dark and/or noisy environments, and suggest that in case new interface technologies are explored in the future, “rather than to copy the haptic properties of the mechanical interface, such a new interface should encompass the new functionality of the automatic engine control and utilize the potential of the haptic feedback technology.” This is a very interesting suggestion, but has been largely left unexplored.

In short, not much attention has been given to support ship control with haptics. To explain the work reported in this paper it is relevant to schematically explain the differences between manual control, autopilot control and haptic control of a ship with azimuth thrusters.

Figure 1(a) shows a high level block diagram of a human operator controlling the azimuth thruster levers manually. The ‘human’ is shown in green and gets mainly visual feedback of the situation. This is compared with an abstract plan (ref) in the outer loop (trajectory) controller, and leads to two reference values for ship

speed ($v_{s,ref}$) and direction (χ_{ref}). The difference of these reference values and their actual values (v_s, χ) are inputs (e_v, e_χ) to the human inner loop controller, that applies forces ($F_{n,op}, T_{\delta,op}$) to move the levers. The lever positions result in setpoints for the ship (n_{set}, δ_{set}). The ship will accelerate and/or turn and the human will react to this.

Figure 1(b) shows the situation where the autopilot controls the direction of the ship. The speed is still controlled as in Figure 1(a). There are various ways in which an autopilot can work. In this case the human operator enters waypoints into the electronic navigation chart, which subsequently provides a bearing (χ_d) of the next waypoint to the autopilot. The autopilot compares this bearing with the actual direction, and calculates a thruster angle setpoint ($\delta_{set,ap}$) which is directly sent to the ship without interference by the human.

In Figure 1(c) the haptic approach is shown. In this case the autopilot provides its setpoint to a haptic algorithm, which determines the torque ($T_{\delta,ha}$) that it applies to the azimuth angle lever. The human operator also applies a torque ($T_{\delta,op}$), and the total torque (T_δ) results in lever movement. Hence, the human operator and the autopilot both control the ship by exerting forces on the input device. This physical coupling allows one to “feel” the inputs of the other. Note that the proprioceptive feedback to the human is not shown in the diagram and that the haptic feedback in the engine speed lever ($F_{n,ha}$) is dotted because this paper focuses on ship direction control.

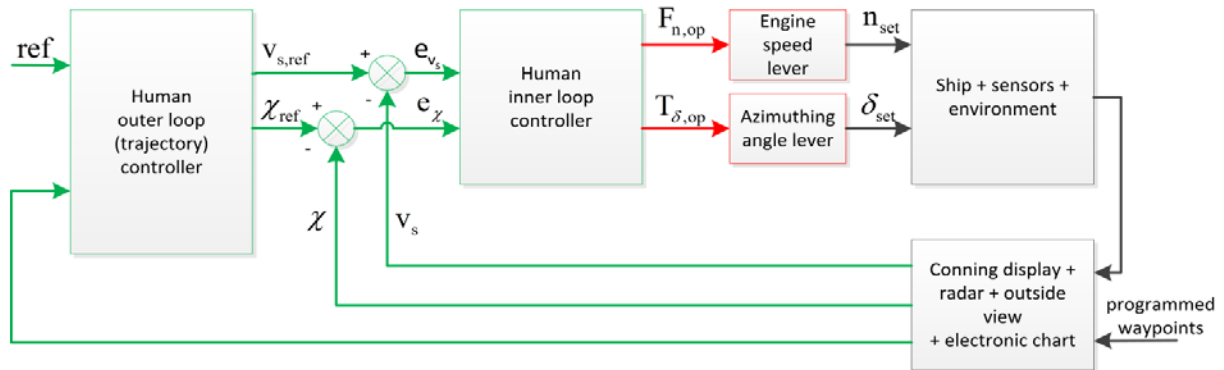

Figure 1(a) Manual control.

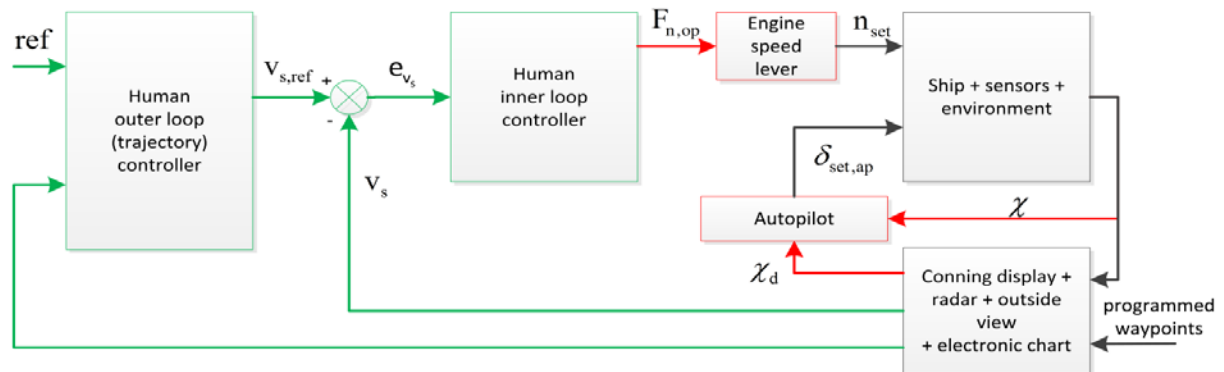

Figure 1(b) Autopilot.

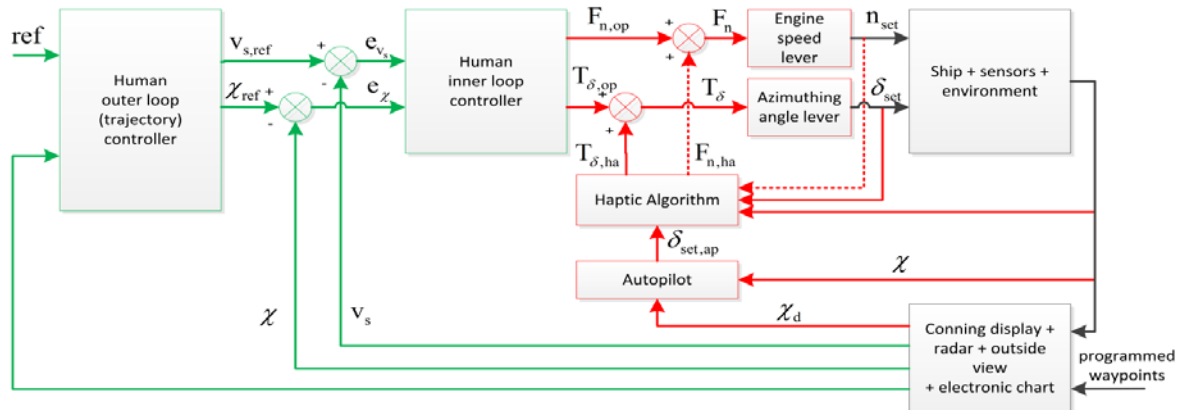
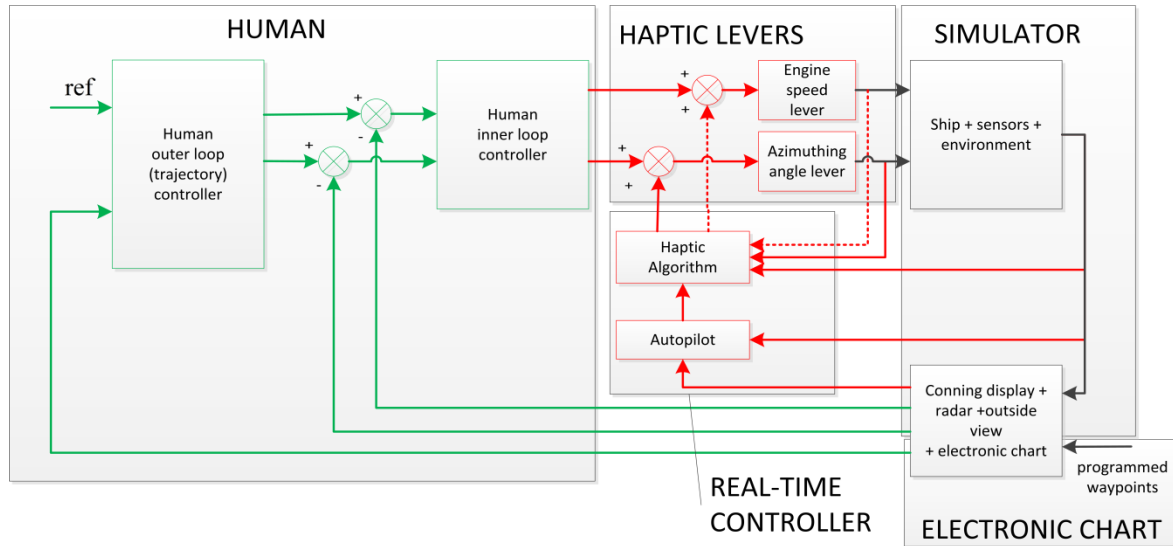

Figure 1(c) Proposed haptic guidance approach for steering assistance.

Figure 1 depicts the simplified schematic overview for three ways controlling a ship. Green blocks denote the human operator, red blocks denote the control units and corresponding underlying algorithms, and black blocks denote the ship and environment.

4. The Haptic Ship Simulator

This section describes the novel haptic maritime simulator setup that has been designed and built at Delft University of Technology. Similar to the schematic overview shown in Figure 1(c), the components are shown in Figure 2(a) and the actual setup is shown in Figures 2(b) and 2(c). Each component is elaborated upon separately in this section.



(a) Schematic Overview of the Haptic Ship Simulator setup and its components.

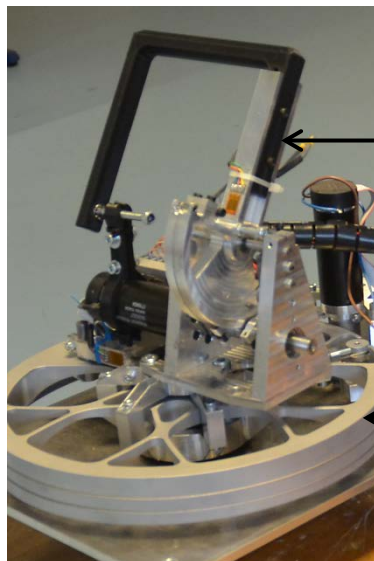

(b) Close-up of one Haptic Lever: the black RPM lever and the grey azimuth angle disc.

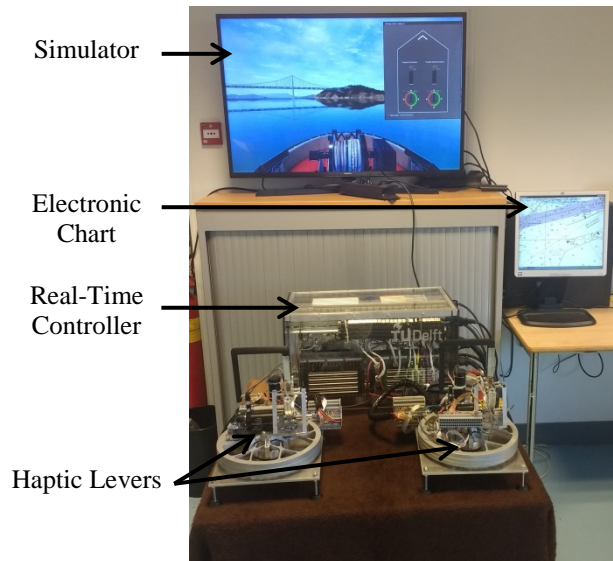

(c) The complete setup, consisting of two haptic levers, a real-time controller, and the simulation environment.

Figure 2. Haptic Ship Simulator: A Schematic Overview (a), the Haptic Levers (b), and the full setup (c).

4.1. Haptic Levers

These custom-made devices were designed and built in the Delft Haptics Lab, using the two 1 Degree-of-Freedom (DOF) levers of an existing custom-made setup (“Gemini”, 2014) mounted on rotational discs. Each Haptic Lever therefore has 2 DOF: a rotation for the RPM Lever, and one for the Azimuth Angle disc on which the RPM lever is mounted. Both rotations are actuated by a separate Maxon motor through steel cables, realising a force and position transmission without noticeable play. The RPM Levers can rotate to 80° forwards and backwards, and the Azimuth Angle disc can rotate 270° in clockwise and counterclockwise direction.

4.2. Human Operator

The human operator controls the two levers and is represented in Figure 2 by an inner-loop controller to control the sailing direction, and an outer-loop controller to close the position loop (control signals shown in green). This scheme shows the visual feedback loop from the environment and the hardware, but in reality other feedback modalities are important as well (vestibular, auditory, tactile or proprioceptive feedback) but are not shown here to avoid cluttering.

4.3. Real-Time Controller

A Real-Time Controller is required to control the haptic levers. In our setup, a Bachmann® system was used for this, processing the motor encoder information as well as controlling the motor current setpoint for the motor controllers. A model was created in MATLAB® Simulink® (compiled into executable code running at 1 kHz) to read in the lever angles and to translate these into forces based on the Autopilot and Haptic Algorithm, which are also included in this model.

The Real-Time Controller communicates with the simulator and the electronic chart through NMEA 0183 (NMEA, 2002) sentences in order to obtain information of the ship status. Two software modules that are running on the Real-Time controller send and receive these NMEA sentences over Ethernet with the UDP protocol.

4.4. Ship Simulation Environment

The Ship Simulation Environment is a commercial package called NAUTIS®, made by VSTEP Simulation®, which is used in crew training simulators. This software simulates realistic ship behaviour, in various ports and waterways across the globe. It thus simulates the blocks that are indicated in the schematic overview of Figure 2. It also includes simulated sensors and communicates with the Real-Time Controller and the Navigation software through NMEA sentences.

4.5. Electronic Navigation Chart

The software package OpenCPN® is used as the Electronic Navigation Chart. It receives GPS data through NMEA sentences from the Ship Simulation Environment. When a route is activated it can send navigation information such as the bearing of the next waypoint to the Real-Time Controller. This information is used in the ‘autopilot’ depicted in Figure 2.

5. Haptic Feedback Types of the Haptic Ship Simulator

Each of the two haptic levers can be controlled to simulate a wide range of passive dynamics (i.e., stiffness, damping, inertia, friction etc.), as well as to render vibrations and guiding forces.

For a natural feel of the azimuth levers, a constant *damping field* is applied. This way, the lever is resistant against ship vibrations and feels more like commercial devices. In addition to this constant damping field, various haptic functionalities were implemented on the simulator setup, which are described below.

Through *vibrations*, or short force pulses, a warning can be given to the helmsman. This can be used instead of a visual or auditory warning system, for instance to avoid grounding in shallow waters or when deviating too far from the planned track.

Force feedback can be applied through *active constraints*, which were first used by Rosenberg (1993) which he called virtual fixtures. An overview of virtual fixtures, or active constraints, is given by Bowyer et al. (2014). These constraints can be split up in regional and guidance constraints.

Regional constraints are used to communicate no-go zones and operating ranges. A no-go zone is depicted in Figure 3 (left). Another example is enforcing a speed limit, where the RPM lever could be restricted to a certain operating range. The human operator would feel a repulsive force, some sort of virtual ‘wall’ stopping him from giving a command beyond the imposed limit.

Guidance constraints are used to guide the human operator towards a safe or optimal trajectory, as depicted in Figure 3 (right). By limiting the magnitude of the resulting force, the human operator is still able to overrule these constraints.

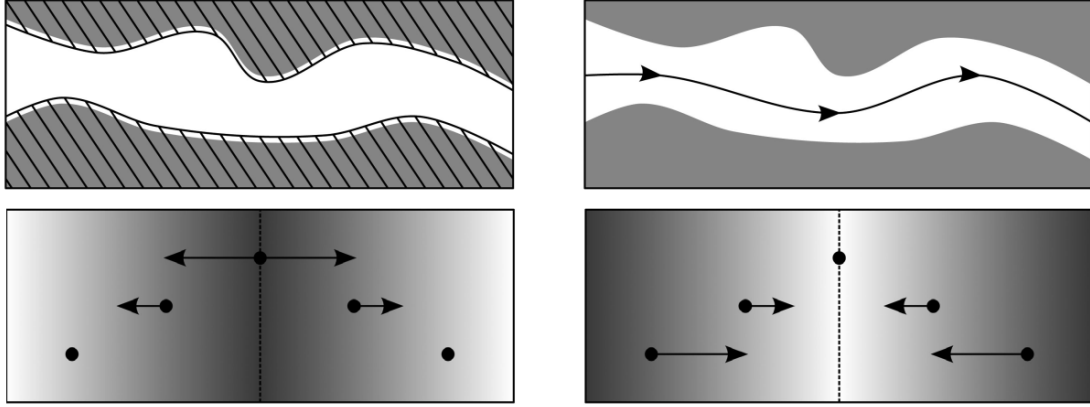

Figure 3. Active Constraints, as illustrated by Bowyer et al. (2014). These can be either regional (left) or guidance based (right). The top figures show obstacles in grey and constraints in black. The bottom figures show the corresponding repulsive forces (left) or attractive forces (right), with darker regions corresponding to larger forces.

6. Application: Navigation Support

Three basic haptic functionalities as described above are implemented in the real-time controller in order to investigate whether the developed setup is suited for exploring the potential of haptics in the maritime environment. To describe the three basic functionalities it is necessary to define the highly simplified navigation task and the variables and parameters involved.

The scenario involves an azimuth stern drive (ASD) tug of approximately 28 m length, sailing in unrestricted and sufficiently deep water. No other vessels or objects are in the neighbourhood. The vessel sails at its maximum ship speed $v_{s,max}$ of around 13 kts. Both thrusters receive the same setpoint for azimuth angle.

The heading of the vessel is denoted by ψ in degrees. Due to wind, waves, current and manoeuvres the heading is not always equal to the course over ground (CoG) of the vessel, which is denoted by χ , also in degrees. The relation between heading and course over ground is given by:

$$\chi = \psi + \beta \quad (1)$$

where β is the sideslip angle. Typically, the heading of the vessel is measured with a (gyro)compass, while the course over ground is an output of the GPS.

The task in this scenario is to sail in a direct line towards a pre-defined waypoint. The bearing (direction) of this waypoint is continuously calculated by the electronic navigation chart based on the location of the waypoint and the instantaneous vessel position as determined by GPS, and is denoted by χ_d . This bearing is used as the desired course over ground and is sent to the autopilot.

The implemented autopilot is a highly simplified version and is solely intended to be used for testing purposes of the setup. Its proportional control law is given by:

$$\delta_{set,ap} = K_{p,ap} \cdot (\chi_d - \chi) \quad (2)$$

where $\delta_{set,ap}$ is the setpoint for the azimuth angle of both thrusters, as determined by the autopilot. $K_{p,ap}$ is the proportional gain of the autopilot. The autopilot setpoint is limited to $|\delta_{set,ap}| \leq 10^\circ$. In the future more realistic autopilots involving integral and derivative terms, as well as other inputs can be implemented.

The passive dynamics consist of virtual hard stops and a damping field. The virtual hard stops limit the operating range to $|\delta_{set}| \leq 15^\circ$. The damping field presents a torque ($T_{damping}$) in the opposite direction to the rotation velocity and is enabled at all times.

$$T_{damping} = K_{damping} \cdot \dot{\delta}_{set} \quad (3)$$

where $\dot{\delta}_{set}$ is the time-derivative of the azimuth angle setpoint, and $K_{damping}$ is the damping coefficient.

The first functionality is a vibration warning on the haptic lever, which is activated as soon as an error boundary is crossed, $|\chi_d - \chi| \geq 5^\circ$. This functionality has no interaction with the autopilot.

The second haptic functionality is a regional constraint that provides repulsive torques (T_{rep}) proportional (K_{rep}) to the error when exceeding the same error boundary. This functionality has no interaction with the autopilot either. Its haptic algorithm is as follows:

$$T_{rep} = \begin{cases} K_{rep} \cdot (\chi_d - \chi), & |\chi_d - \chi| \geq 5^\circ \\ 0, & otherwise \end{cases} \quad (4)$$

The third haptic functionality is a guidance constraint which provides attractive torques. The calculation of these torques makes use of the setpoint as calculated by the autopilot (see equation 2):

$$T_{\delta,ha} = K_{\delta,ha} \cdot (\delta_{set,ap} - \delta_{set}) \quad (5)$$

where the subscript $_{ha}$ stands for haptic algorithm, $T_{\delta,ha}$ is the haptic guidance torque, and $K_{\delta,ha}$ is the proportional gain. This guidance law makes the lever “feel” as if there is a spring connected between the setpoint as enforced by the human operator and the setpoint as intended by the autopilot. In case the user applies no torque to the levers (for instance by letting go), the lever will follow the actual thruster angle as commanded by the autopilot. In the opposite case where the human operator does something completely different from what the autopilot would do, he would notice that by a stronger counteracting torque in the lever.

6.1. Results

Figure 4 shows a 300 second time trace of the application of the haptic functionalities mentioned previously, carried out with one inexperienced human operator. The results are discussed in the next section.

The top graph shows the azimuth angle setpoint δ_{set} , which is a result of the action of both the autopilot and the human. It furthermore shows the azimuth angle setpoint as calculated by the autopilot ($\delta_{set,ap}$) during the guidance functionality. The true azimuth angle is not shown, but has a slight delay compared to the setpoint. Note that both azimuth thrusters were operated in ‘coupled mode’, meaning that one haptic lever was controlling both thrusters simultaneously.

The middle graph shows the true bearing (χ_d) of the next waypoint from the instantaneous position of the ship. In this case the waypoint was far away from the position of the ship, so the signal seems to remain unchanged. The graph also shows the ship’s course over ground (χ), as well as the virtual boundaries at $\chi_d \pm 5^\circ$. Note that the discrete nature of χ is due to the update rate of the simulated GPS signal.

The bottom graph shows the calculated torque in Nm. This setpoint is translated to a required motor current setpoint for the motor controller, which almost instantaneously and continuously adjusts its PWM voltage output in order to supply the required current to the motor. Motor current is approximately linear with motor torque, which is transmitted to the azimuth disc.

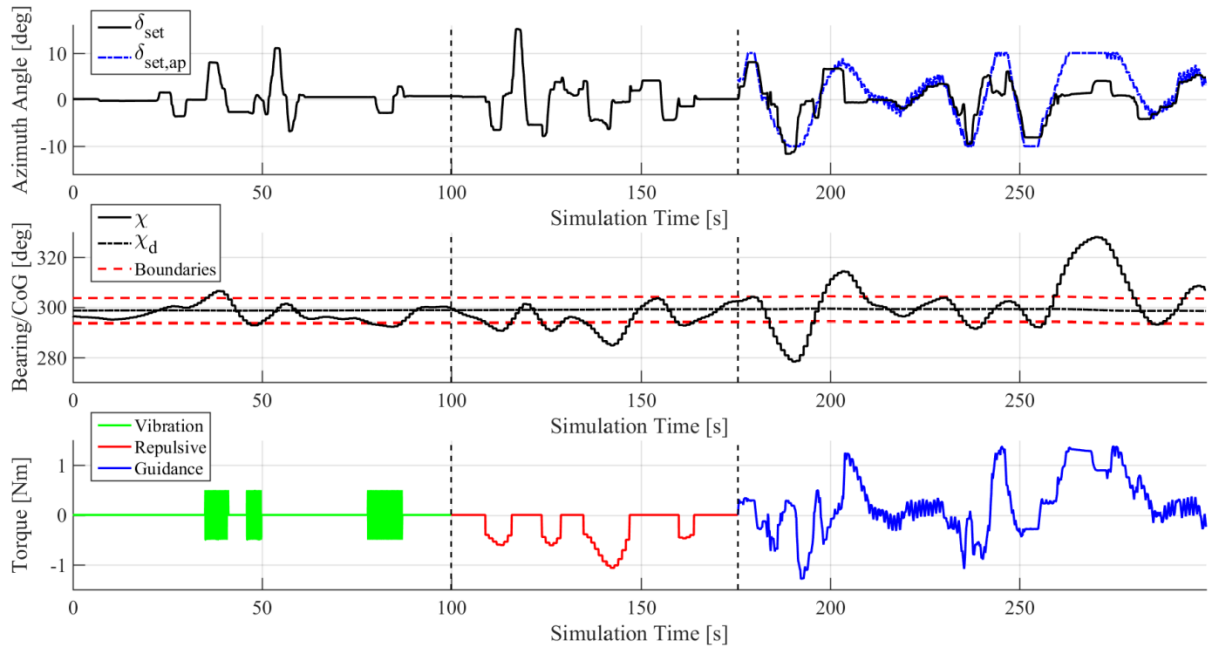

Figure 4: Results of the simple navigation task. The top graph shows the thruster azimuth angle and the autopilot reference angle. The middle graph shows the ship’s Course over Ground (black) and Bearing reference (black dotted) with error boundaries (red dashed). The bottom graph shows the torques and vibrations that are applied when enabling the haptic functionalities.

7. Discussion

In the previous section the possibilities of haptic support of a navigation task were explored in a highly simplified scenario. The experiment has no statistical value and is only intended to explore whether the setup is suited for further exploration of the potential of haptics in the maritime environment and to illustrate its potential

use. Since none of the parameters in both the autopilot and the haptic algorithm were optimised, no conclusions should be drawn based on the performance during the experiment.

In the first 100 seconds the ‘warning vibration’ functionality is tested while the autopilot is not active. As shown, the inexperienced helmsman has difficulties with keeping the ship on course and around $t=40s$ crosses the safety boundary. Consequently a warning vibration is given, and the helmsman gives a substantial thruster angle command of around 8° , after which the tug starts to turn to port. Note that the ship reacts very fast because it is an ASD tug, which is known to be very responsive. The correction results in an undershoot of the course over ground which is communicated by a second vibrating warning. After another short correction by the helmsman the ship sails roughly in the right direction until around $t=80s$ another warning is given.

From $t=100$ to $t=175s$ the vibration warning is replaced by the repulsive guidance functionality, during which the autopilot remains inactive. The repulsive guidance only becomes active when the error exceeds safety margins, here happening at four intervals, leading to a torque over the rotation axis. As shown in the graph, the size of the torque is dependent on the error of the course over ground, in line with equation 4.

From $t=175s$ to the end the attractive guidance is activated. This type of haptic guidance requires the autopilot functionality because it requires $\delta_{set,ap}$ as input. In this case the haptic algorithm is continuously providing feedback to the operator. This algorithm is driven by the difference between $\delta_{set,ap}$ and δ_{set} , as was shown in equation 5. The top graph shows that the operator follows the autopilot in the beginning, but around $t=265s$ decides not to follow the autopilot, resulting in a large error as shown in the middle graph.

The experiment as reported in this paper should be seen as a first test of the suitability of the developed experimental setup to explore the potential of haptics for the maritime environment and as an illustration of potential design options for haptic support. The three developed haptic support features, based on highly simplified haptic algorithms and autopilot models, showed that the developed setup generates haptic feedback on the azimuth angle lever as expected. Although not reported here, similar tests were performed with the engine speed lever. Based on this it is concluded that the experimental setup is ready to be used for exploration of more realistic operations and scenarios, with more intelligent haptic control algorithms, and extensive human-in-the-loop experiments.

The NAUTIS bridge simulator environment is flexible in providing different kinds of sensor information to the haptic algorithm which allows exploring a variety of haptic support features. Such features can range from relatively simple to highly complex and safety critical. For example, through feedback of the actual lever status Natural Force Feedback can be realised, enabling the bi-directional haptic interaction mentioned in Section 2.

In the near future it is foreseen to further develop haptic support of navigation tasks, which includes collision and grounding avoidance as well as speed management features. Furthermore operations that involve approaching fixed structures such as for instance offshore wind turbines, locks, and quay walls are seen as potentially interesting cases to apply haptic support. In the less near future it is foreseen to investigate the potential of haptic support of complex operations such as for instance a harbour tug in escorting mode. Such escorting operations involve (subtle) balancing of various forces and moments (due to hull, thruster and towline) and might benefit from haptic support.

Application of haptic support might furthermore offer possibilities for support of remote control of future semi-autonomous ships. A remote control operator does not have the same ‘presence’ as an onboard operator would have. Providing haptic feedback might help to decrease this lack of ‘feeling’ with the controlled vessel.

8. Conclusions

The setup as described in this paper has been built and tested. The basic tests that are reported in this paper show that the hardware, software and their interfaces work. They also show that the autopilot and haptic algorithms can be changed and tuned, such that the researchers have full control over the experimental setup. Overall it is therefore concluded that the developed maritime haptic simulator allows for human-in-the loop experiments to explore potential benefits of haptic feedback for maritime applications.

9. Acknowledgements

This work was sponsored by a cohesion grant awarded by the Dean of the 3mE Faculty of Delft University of Technology. We thank Alfons Schure for designing and building the azimuth disc extension, and Roel Kuiper for his valuable advice during this project. We also acknowledge the support of Bachmann electronic GmbH for the real-time control solution required for haptic simulation. We thank VSTEP B.V. for kindly providing the maritime simulation software and support.

10. References

- Abbink, D. A., Mulder, M., & Boer, E. R. (2012). Haptic shared control: smoothly shifting control authority?. *Cognition, Technology & Work*, 14(1), 19-28.
- Bias, R., Lewis, C., & Gillan, D. (2014). *The tortoise and the (soft) ware: Moore's law, Amdahl's law, and performance trends for human-machine systems*. *Journal of Usability Studies*, 9(4), 129-151.
- Billings, C. E. (1997). *Aviation automation: The search for a human-centered approach*. Mahwah, NJ: Erlbaum
- Bjelland, H. V., Roed, B. K., & Hoff, T. (2005, March). Studies on Throttle sticks in high speed crafts-haptics in mechanical, electronic and haptic feedback interfaces. In *Proceedings of the First Joint Eurohaptics Conference and Symposium on Haptic Interfaces for Virtual Environment and Teleoperator Systems, 2005. World Haptics 2005*. (pp. 509-510). IEEE.
- Boessenkool, H., Abbink, D. A., Heemskerk, C. J., van der Helm, F. C., & Wildenbeest, J. G. (2013). A task-specific analysis of the benefit of haptic shared control during telemanipulation. *IEEE Transactions on Haptics*, 6(1), 2-12.
- Bowyer, S. A., Davies, B. L., & y Baena, F. R. (2014). Active constraints/virtual fixtures: A survey. *IEEE Transactions on Robotics*, 30(1), 138-157.
- Donaldson, J. F., Rendle, J., & McIntyre, A. D. (1994). *Safer ships, cleaner seas: report of Lord Donaldson's inquiry into the prevention of pollution from merchant shipping*. HMSO.
- “Gemini” – Dual 1 DOF master devices. (2014). Retrieved from <http://www.delfthapticslab.nl/device/gemini-1dof-master-slave/>
- Griffiths, P. G., & Gillespie, R. B. (2005). Sharing control between humans and automation using haptic interface: primary and secondary task performance benefits. *Human factors*, 47(3), 574-590.
- van de Merwe, F., Kähler, N., & Securius, P. (2016). Crew-centred Design of Ships–The CyClaDes Project. *Transportation Research Procedia*, 14, 1611-1620.
- Mugge, W., Abbink, D. A., Schouten, A. C., Dewald, J. P., & van der Helm, F. C. (2010). A rigorous model of reflex function indicates that position and force feedback are flexibly tuned to position and force tasks. *Experimental brain research*, 200(3-4), 325-340.
- Mulder, M., Mulder, M., Van Paassen, M. M., & Abbink, D. A. (2008). Haptic gas pedal feedback. *Ergonomics*, 51(11), 1710-1720.
- Mulder, M., Abbink, D.A., & Boer E.R. (2012). Sharing Control With Haptics: Seamless Driver Support From Manual to Automatic Control. *Hum. Factors J. Hum. Factors Ergon. Soc.*, vol. 54, no. 5, pp. 786–798, 2012.
- National Marine Electronics Association. (2002). *NMEA 0183--Standard for interfacing marine electronic devices*. NMEA.
- Prada, V., Conde, G., Figueredo, A., Sánchez, J., & Santos, A. (2016). Modeling and Control of a Haptic Lever to Regulate the Speed in Maritime Vehicles. In *Applied Mechanics and Materials* (Vol. 835, pp. 718-722). Trans Tech Publications.
- Rosenberg, L. B. (1993, September). Virtual fixtures: Perceptual tools for telerobotic manipulation. In *Virtual Reality Annual International Symposium, 1993., 1993 IEEE* (pp. 76-82). IEEE.
- Sheridan, T. B. (2002). *Humans and automation: System design and research issues*. John Wiley & Sons, Inc..
- de Stigter, S., Mulder, M., & Van Paassen, M. M. (2007). Design and evaluation of a haptic flight director. *Journal of Guidance Control and Dynamics*, 30(1), 35.